

ET-01 TIMER

WIRING INSTRUCTIONS

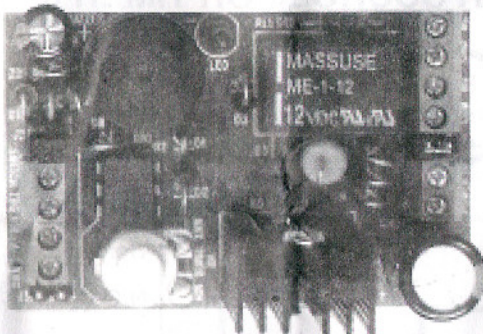

The ET-01 timer is the one timer that handles all your entry applications. The ET-01 is designed to accept a wide range of operating voltages and trigger modes, and its output can be tailored to the application. Variable output time and a built-in piezo sounder complete the package.

Terminals:

Power In - Connect AC or DC voltage to these terminals (12-24V depending on magnet or strike used.

IMPORTANT: When using AC power source, use 12VAC for 12VDC magnetic lock - Do not exceed 12VAC input for 12VDC magnetic lock; use 16-20VAC for 24VDC magnetic lock - Do not exceed 20VAC input for 24VDC magnetic lock!).

C NO NC - This form C relay is a wet voltage contact; when you remove jumper J1 it becomes a dry contact relay

GND and NC- Voltage out for magnetic locks

GND and NO - Voltage out for electric door strikes

Voltage Trigger - When selected by jumper J3, apply 12-24 Volts AC or DC to trigger timer.

OR*

Switch Trigger - When selected by jumper J2, connect a normally open switch to these terminals.

*(*Please note: One trigger mode must be selected by jumpers J2 & J3. If the jumper is placed on J2 switch trigger is selected, on J3 voltage trigger is selected. You can use either the switch or the power trigger, but not both in the same application!)*

Building Entrance Connection:

Wire the exit switch and the key entry switch in series with one leg of the power inputs & adjust the timer to the amount of time you want (1-60 sec.).

WIRING DIAGRAM #1: FOR MAGNETIC LOCK USING SAME POWER SOURCE FOR TIMER & LOCK

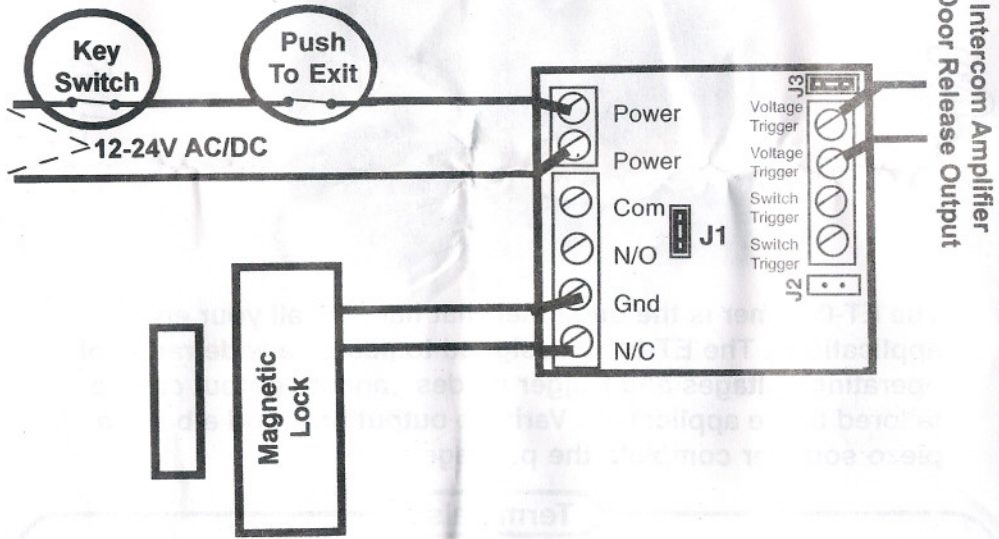

WIRING DIAGRAM #2: FOR ELECTRIC DOOR STRIKE USING SAME POWER SOURCE FOR TIMER & LOCK

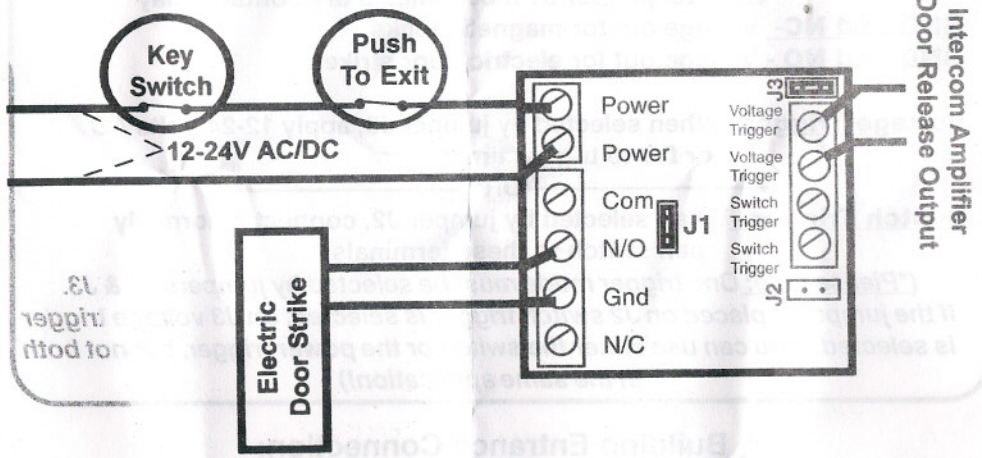

Wire the exit door strike key entry switch in series with the power input to the timer to the amount of time you want (1-60 sec.).

WIRING DIAGRAM #3:

FOR MAGNETIC LOCK USING SEPARATE POWER SOURCES FOR TIMER & LOCK

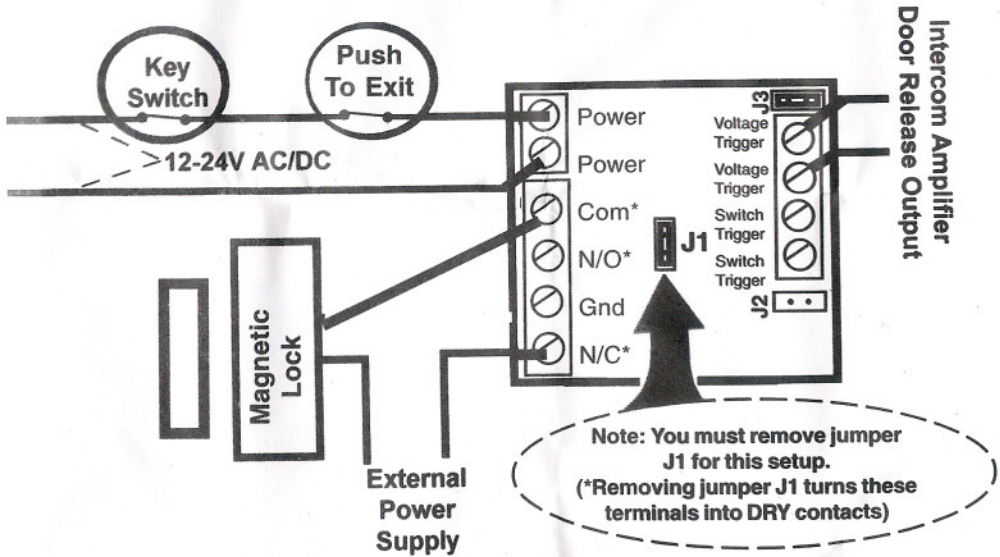

WIRING DIAGRAM #4:

FOR ELECTRIC DOOR STRIKE USING SEPARATE POWER SOURCES FOR TIMER & LOCK

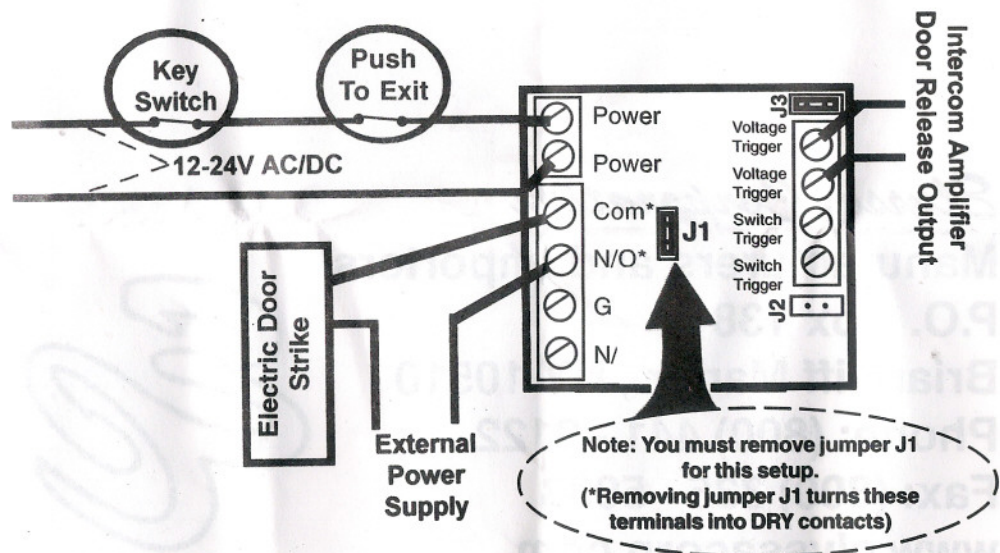

Elyssa Corporation

Manufacturers and Importers

P.O. Box 138

Briarcliff Manor , NY 10510

Phone: (800) 441 - 9122

Fax: (800) 335 - 5933

www.elyssacorp.com

